

## 経営方針

当社は、自動車部品・産業用部材の販売及び製造に従事する上で、以下の項目を実践することを通じ、顧客要求を満足すべく、迅速かつ的確に活動することを宣言する。

1. 外部状況、内部状況を見据えた上での品質・環境目標設定とレビューによる継続的改善。
2. 法規制、及び当社が同意した外部からのその他要求事項の順守。
3. 事業活動に伴う環境影響を見据え、環境汚染を予防し、環境保護に貢献する。

2016年10月1日

代表取締役社長 米田豊克

## 組織図・サイトマップ

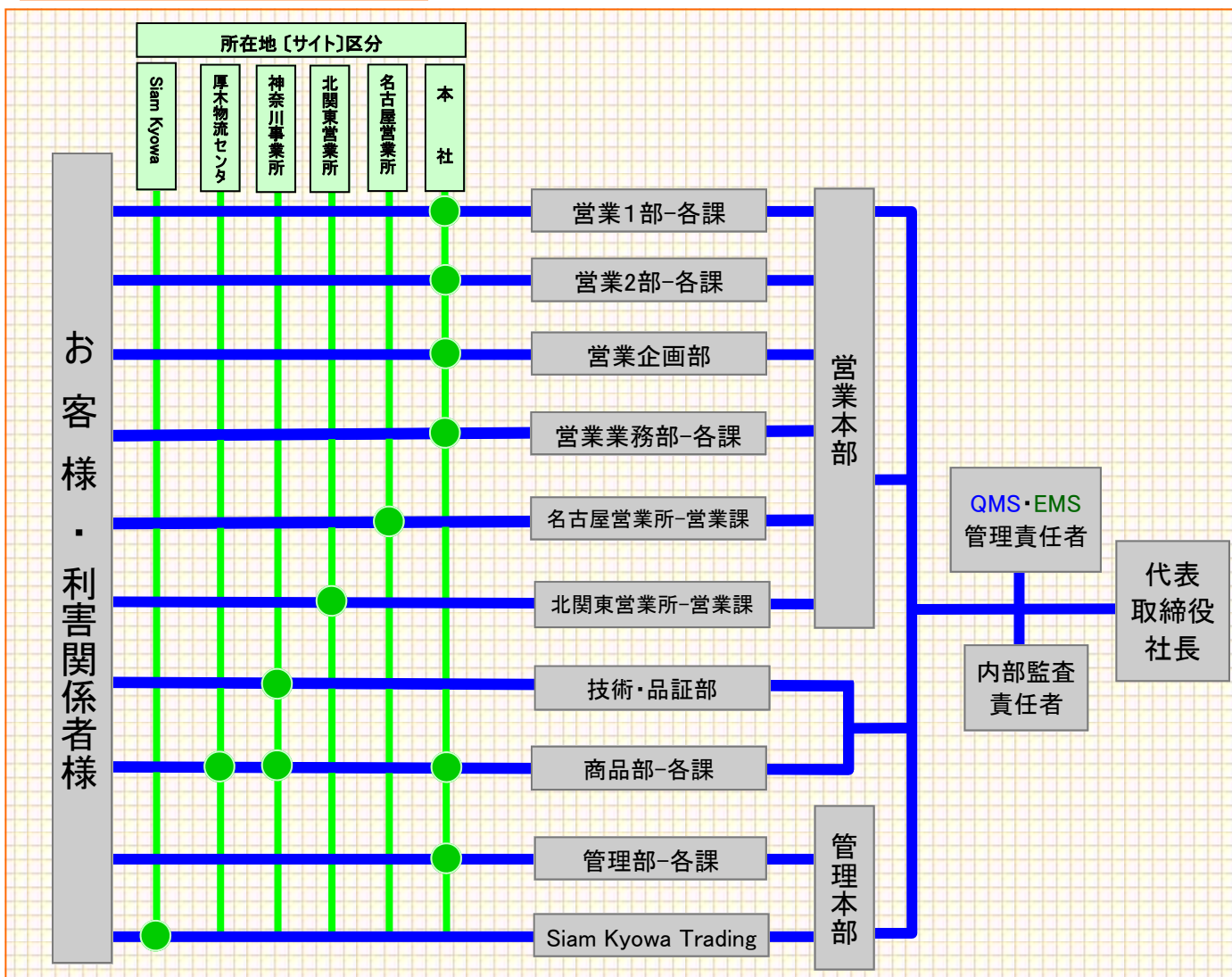

## Management Policies

We declare on engaged in selling and manufacturing of automotive parts and industrial element, through to be practice the following topics, in order to satisfy the customer request, to be activities quickly and accurately.

1. We anticipate of the external and internal context and to implement a continuous improvement by target setting and review of the issues of quality and the environment.
2. We will comply with the requirements of the Laws and regulations and the other that we have agreed.
3. We observe the environmental impact associated with business activities, to prevent environmental pollution, to contribute to the environmental protection.

## Organization Map Sites Map

1/Oct/2016

President T. Yoneda

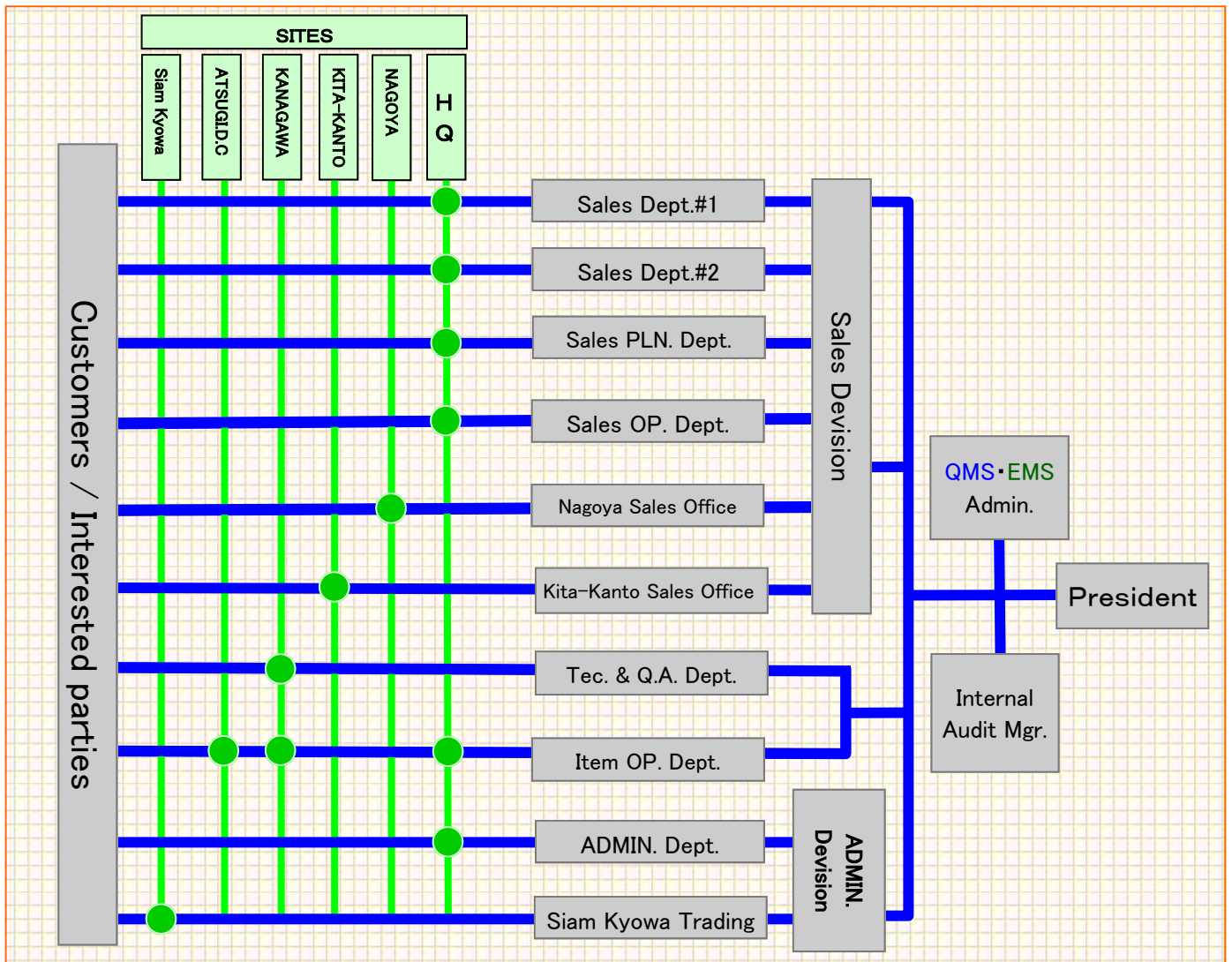

# 品質・環境マネジメントシステム概念図

QMS EMS Overview

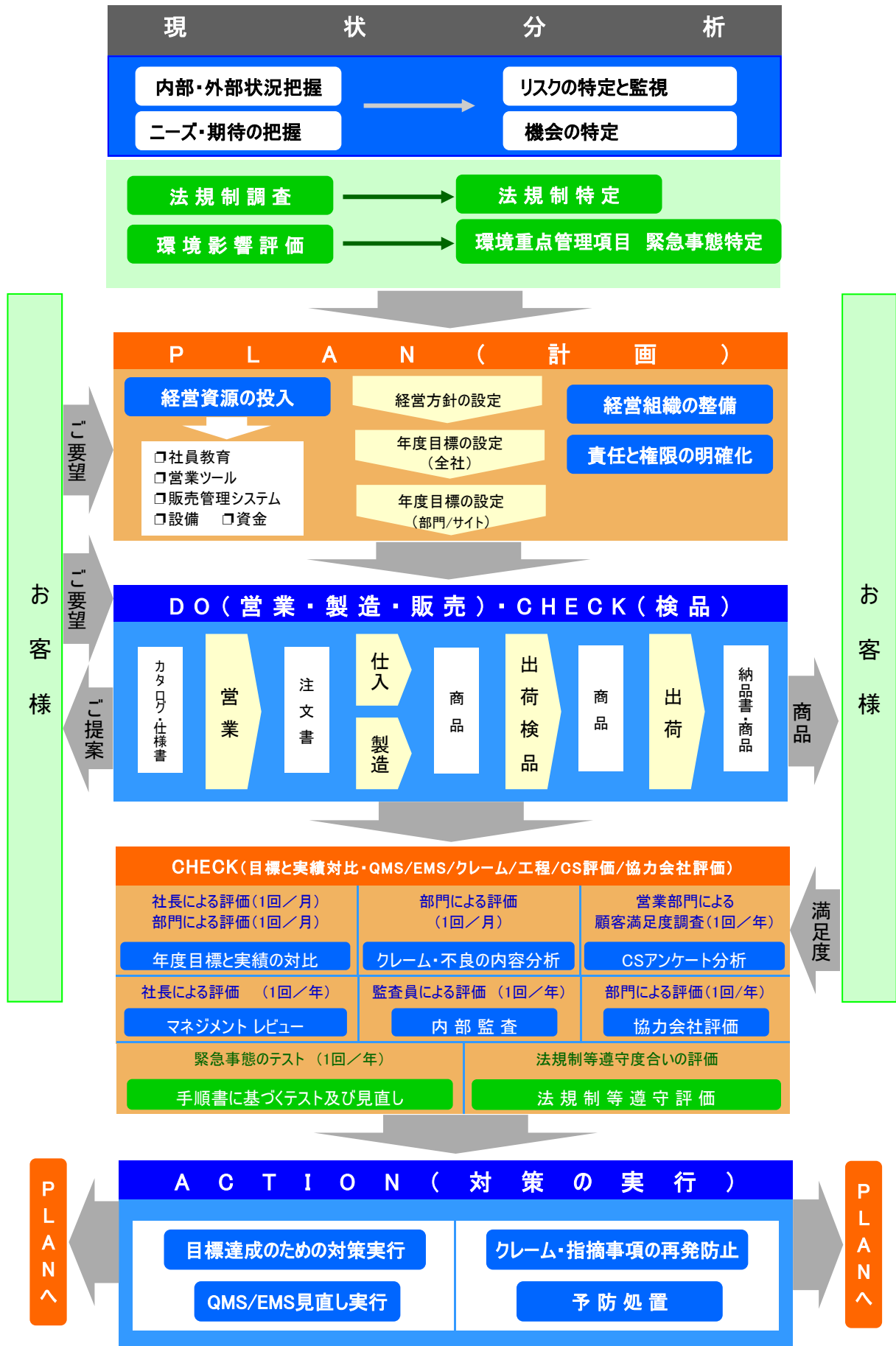

# QMS EMS Overview

A n a l y s i s   t h e   c u r r e n t   c o n t e x t

Understanding of the internal and external context

Identification and monitoring of the risk

Understanding of the needs and expectations

Identifying the opportunity

Survey of laws and regulations

Identify laws and regulations

Environmental impact assessment

Specific environmental management items and emergency

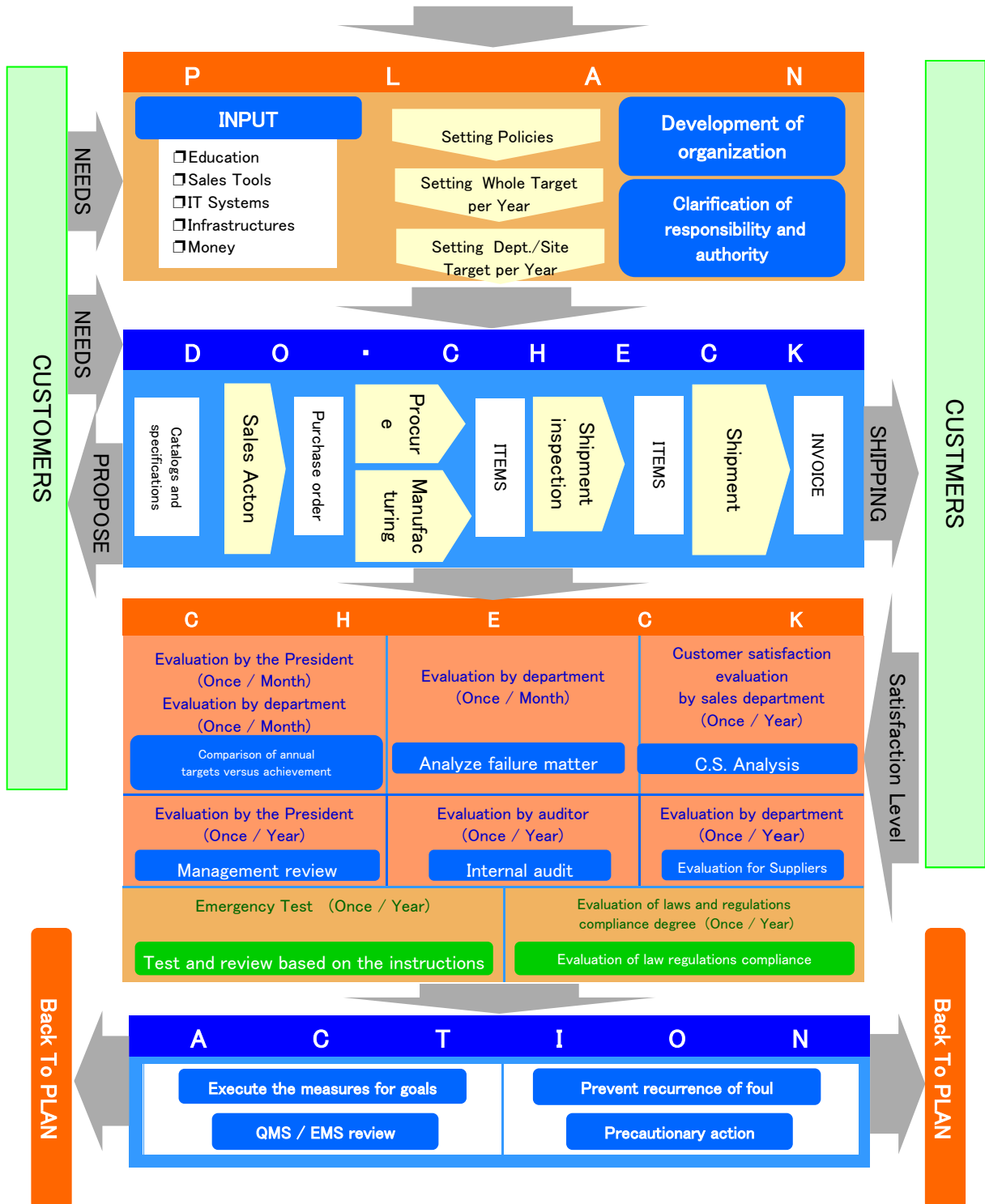

## 業務運営上のマニュアル

Manuals in Work Operations

文書名	内容	規格の要求事項
共通ルールブック	責任及び権限、経営資源、目標管理、能力開発、マネジメントレビュー、顧客満足、不適合への対応・再発防止、リスク及び機会への対応、内部監査、文書化した情報、環境影響評価・法規制遵守・緊急事態、内部・外部コミュニケーション	ISO9001:2015 ISO14001:2015 5/6.1/6.2/7/8.2/ 8.7/9.1.2/9.2/9.3/ 10.2
個別業務マニュアル	営業・業務、製造、品質保証、管理、企画 環境手順書、緊急事態手順書	ISO9001:2015 ISO14001:2015 7.5.2/8/8.1/8.2/ 9.1/10.2
管理文書・様式・記録一覧表	文書化した情報の管理 配布・アクセス・検索・利用 保管・保存、変更管理 保持及び廃棄	ISO9001:2015 ISO14001:2015 7.5.2/7.5.3

## 主要商品群

Main Items

- 自動車車載部品
- プリント配線板材料
- 工業用ゴム加工品・工業用材料
- FA産業機器 ケミカル関連商品

## Manuals in Work Operations

Document name	Contents	Requirements of the standards
Basic rule book	Responsibilities and authorities Resources Management by objectives Skills development Respond to claims/ Preventive action procedure Actions to address risks and opportunities Documented information Environmental impact assessment Compliance with laws and regulations Emergency Internal Communication External Communication	ISO9001 : 2015 ISO14001 : 2015 5/6.1/6.2/7/8.2/ 8.7/9.1.2/9.2/9.3/ 10.2
Individual operations manuals	Procedures of: :Sales and operations :Manufacturing :Quality assurance :Planning :Administration Environmental procedures Emergency procedures	ISO9001 : 2015 ISO14001 : 2015 7.5.2/8/8.1/8.2/ 9.1/10.2
Management documents, Forms and records list	Control of documented information: Distribution/ Access/ Retrieval and use Storage and preservation Control of changes Retention and disposition	ISO9001 : 2015 ISO14001 : 2015 7.5.2/7.5.3

## Main Items

- Automotive parts & units
- Material of printed circuit board
- Industrial rubber processing products and industrial materials
- FA industrial equipment chemical related products

お客様からのクレーム対応手順  
Procedure For Complaint From Customer

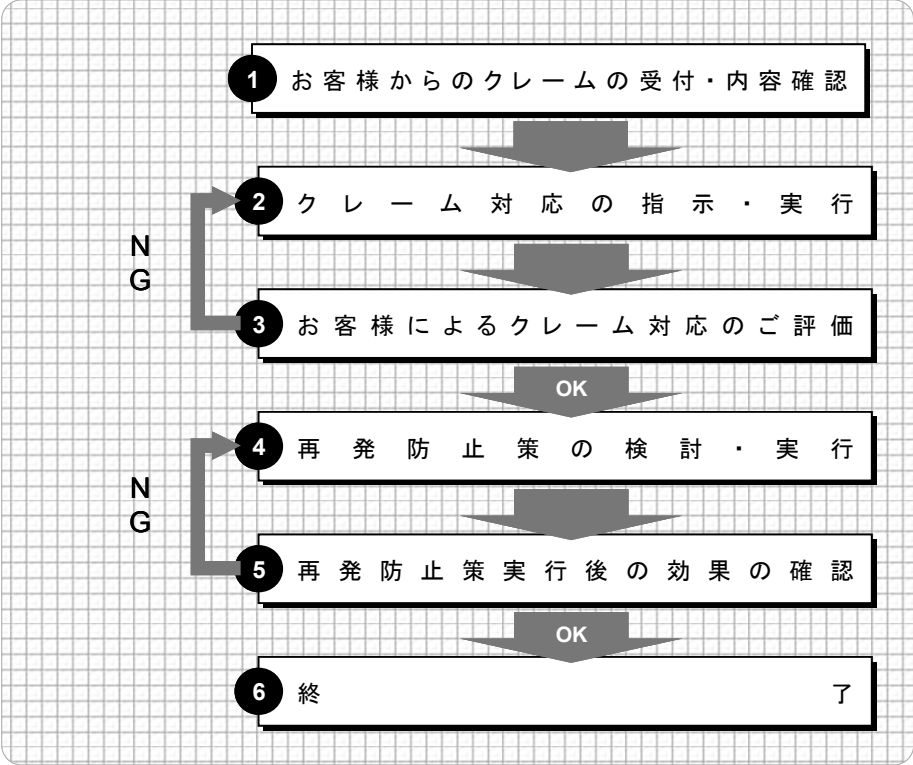

お客様満足度アンケートのお願い  
Customer Satisfaction Rating Questionnaire

当社ではお客様満足度の向上のため、継続的に活動を行っております。  
その一環として、お客様満足度調査票を基に改善活動を実施させていただきます。  
(実施時期 年1回 7月)

品質・環境マネジメントシステム適用範囲  
Scope

- 1 **サイト/部署(QMS・EMS)**  
本社、神奈川事業所、厚木物流センター、名古屋営業所、北関東営業所、SIAM KYOWA TRADING CO., LTD. (THAILAND)、及び各サイト所在部署
- 2 **製品・業務**
  - ・自動車部品の販売及び製造(QMS・EMS)
  - ・産業用部材の販売及び製造委託管理(QMS・EMS)
- 3 **対象(QMS・EMS)**  
正社員、派遣・契約社員、パートタイマー
- 5 **適用範囲外の業務(QMS)※**  
ISO9001:2015 8.3 製品及びサービスの設計・開発
- 6 **除外の理由(QMS)**  
当社の商品・サービスはお客様の仕様に基づいてご提供するものであり、設計開発業務が不要であるため除外いたします。  
(※将来要求事項に該当する際に改訂)

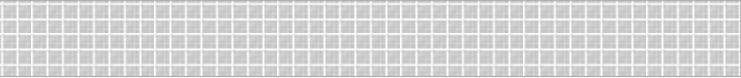

承認	審査	起案
米田 (克)	秋本	米田 (章)

## Procedure For Claims From Customer

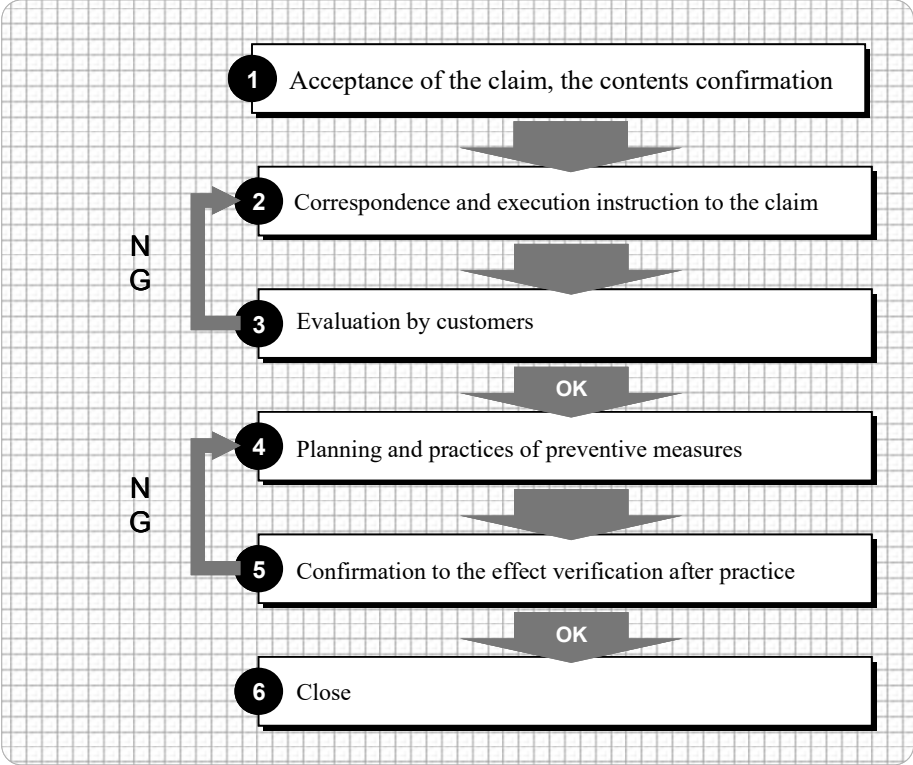

## Customer Satisfaction Rating Questionnaire

Order to improve customer satisfaction, we have made a continuous activity in our company. As part of these efforts, we will implement the improvement activities based on the customer satisfaction rating questionnaire. (implementation period : Once in July / year )

## Scope

- 1 Sites/Department(QMS・EMS)  
 H.Q. Kanagawa Office Atsugi D.C.  
 Nagoya Sales Office Kitakanto Sales Office  
 SIAM KYOWA TRADING CO., LTD. (THAILAND)  
 Department in each sites
- 2 Products and operations
  - ・ Automotive parts sales and manufacturing (QMS・EMS)
  - ・ Sales and contract manufacturing management of industrial members (QMS・EMS)
- 3 Personnel of the target(QMS・EMS)  
 Regular employees,  
 Temporary or contract employees,  
 Part-time workers
- 5 Operation of outside scope(QMS)※  
 ISO9001:2015 8.3 Design and development of products and services
- 6 The reason that was outside the scope(QMS)  
 Our products and services are intended to provide based on customer's specifications, will be excluded because design and development operations is not required.  
 (※In future, revised to the time that corresponds to the requirements)



Approved	Reviewed	Drafted
米田 (克)	秋本	米田 (章)